



# Sign Cap

Designed to support operational requirements and traffic management needs.

From Health & Safety notices to directing traffic, the sign cap supports your factory flow and processes. Using universally-recognised signage, it is positioned at the optimum height to be visible to both moving traffic and pedestrians.

The fully-customisable product seamlessly integrates into the A-SAFE product range, providing you with a comprehensive Health & Safety solution.



**Ultra-low maintenance** material is chemical and water resistant, non-corrosive and non-scratch so no cracking, rusting, flaking or corrosion.

**Self coloured and UV stabilised** for long lasting aesthetics with no repainting required.

**H&S compliance** is emphasised ensuring workers and visitors are aware of safety procedures in the required locations.

**Compatible sign** inserts are available separately to suit your needs.



Material Properties	MEMAPLEX™
Temperature Range	-20°C to 50°C
Ignition Temperature	330°C to 410°C
Flash Point	341°C
Toxicity	Not Toxic
Chemical Resistance	Excellent - ISO/TR 10358
Weathering Stability (Grey Scale)	5/5*
Light Stability (Blue Wool Scale)	7/8**
Static Rating (Surface Resistivity)	Insulator ( $1 \times 10^{11} \Omega/SQ$ )
Hygiene Seals	No

\* Weathering scale 1 is very poor and 5 is excellent

\*\* Light stability scale 1 is very poor and 8 is excellent

## Technical Information

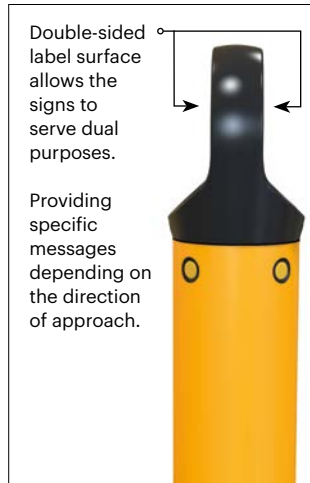
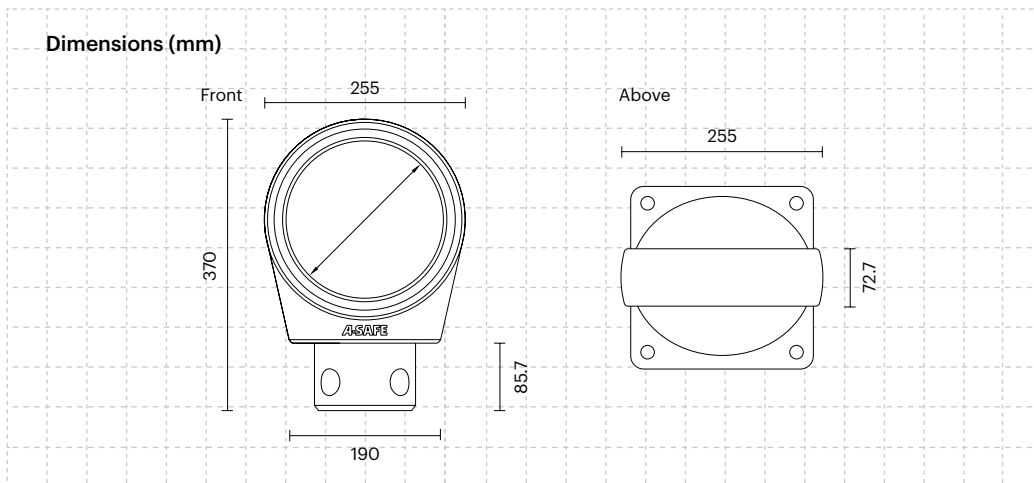

## Colour Options



\*Please note that the RAL and PANTONE colours listed are the closest match to standard A-SAFE colours, but may not be exact matches of the actual product colour and should be used for guidance only.

